



0230-0178D

PO BOX 4394
SANTA ROSA, CA
95402 USA

P (707) 525-9941
F (707) 575-7046
EMGPICKUPS.COM

X-SERIES

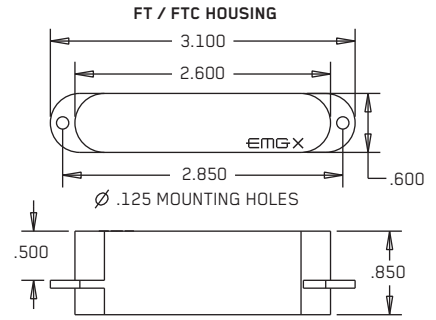
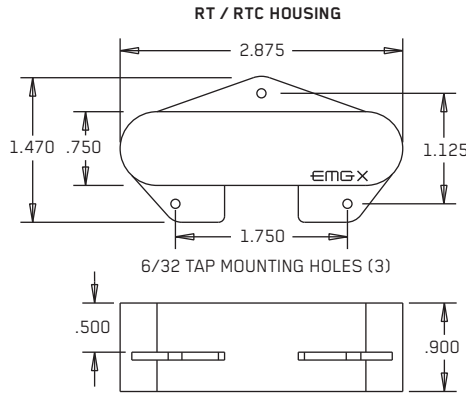

INSTALLATION INFORMATION EMG MODELS: T-X & TC-X SETS

SPECIFICATIONS:

	FT-X Pickup	RT-X Pickup	FTC-X Pickup	RTC-X Pickup
Logo Color	Gold	Gold	Silver	Silver
Magnet Type *	A	A	C	C
Resonant Frequency (KHz)	4.52	2.58	5.30	4.02
Output Voltage (String)	1.00	2.00	1.00	2.00
Output Voltage (Strum)	3.00	4.00	3.00	4.00
Output Noise (60 Hz)	-101	-101	-103	-103
Output Impedance (Kohm)	2	2	2	2
Maximum Supply (Volts DC)	27	27	27	27
Pickup Set Specifications:				
Current @9V (Microamps) (Set)	810			
Battery Life (Hours) (Set)	300			

*Note: Magnet Type: A (Alnico) C (Ceramic)

INSTALLATION NOTES:

The T-X and TC-X Pickup Systems are designed to directly replace the pickups in a Telecaster* type guitar. There are two distinct pickups included in the System. The FT-X (Front Tele) pickup is small and can mount in the body with wood screws (older guitars) or into the pickguard using screws and springs (newer guitars). Hardware is included for either style of installation. The T-X System uses Alnico magnets for a fuller sound, while the TC-X uses Ceramic magnets for a brighter sound. There are some Telecaster style guitars where the battery will not fit into the control cutout, the newer instruments are computer routed and usually a battery will fit where shown in the diagrams. Before installing the EMG Pickups and controls, it is recommended that you determine if the battery will fit or not and make a decision about either routing the control compartment larger, or perhaps installing a battery holder in the rear of the instrument (recommended).

IMPORTANT INSTALLATION NOTES:

- 1) Only one 9-Volt battery is required to power the pickups and any accessories such as the SPC, EXG, VLPPF, and RPC Controls. Use an Alkaline or Lithium battery for longest life.
- 2) The Volume and Tone controls included with this EMG System are 25K Ohm. This value is required for the system to work correctly.
- 3) A stereo output jack (12B) is included with the EMG Pickups; it grounds the black battery wire to turn on the pickups when the plug is inserted into the jack. If you are replacing passive pickups, make sure to use the jack included. If your guitar has a long panel jack make sure it is a stereo type, a Switchcraft 152B is recommended.
- 4) When installing EMG Active Pickups, DO NOT connect the bridge ground wire. This wire is usually soldered to a volume or tone control casing and goes to the bridge. This wire grounds the strings and uses them and your body as a shield against hum and buzz. It also creates a shock hazard.

EMG Pickups are shielded internally and DO NOT require string grounding. This greatly reduces the possibility of reverse polarity shock from microphones and other equipment.

- 5) EMG Active Pickups have very little magnetism compared to passive pickups. We recommend you adjust the pickups as close to the strings as possible. Sustain and string movement will not be inhibited by close adjustment.
- 6) If your installation is different from the diagrams in these instructions or you need additional diagrams visit our website: emgpickups.com for a complete listing of available diagrams.

7) SPECIAL NOTE:

The diagrams shown are for EMG Active Pickups. All diagrams show the Red Wire coming from the pickups connected to the battery. If you are installing EMG-HZ Passive Pickups refer to their diagrams. The Red Wire of the HZ Pickup is NOT for battery power, it is a coil wire.

WARRANTY

All EMG Pickups and accessories are warranted for a period of two years. This warranty does not cover failure due to improper installation, abuse or damage. If upon examination the pickup is determined to be defective, a replacement will be made. Warranty replacement products are covered by this same warranty. This warranty covers only those pickups and accessories sold by authorized EMG Dealers. This warranty is not transferable.

Installation Instructions:

EMG Models: T-X & TC-X SET

General Notes:

Every attempt has been made to make this a solderless installation.

There are some instances where this is not possible;

- 1) If your instrument uses the long panel output jack and you had passive pickups you will need a new stereo output jack, the Switchcraft 152B is recommended. Soldering to the new jack will be required, see Diagram #13 on page 4.
- 2) Make sure the battery fits into the instrument control compartment before you proceed with the installation. It may be necessary to enlarge the control compartment in both width and depth to fit the battery and controls. A separate battery compartment on the back of the instrument is always recommended.

Step 1:

- 1) Remove the strings from the instrument. Remove the existing controls and switch from the control plate by cutting the pickup wires at the switch. Also cut the wires to the output jack and remove it. Cut the ground wire coming from the bridge, it will not be reconnected. Unscrew and remove the pickguard. The fingerboard pickup may or may not be attached to the pickguard. Remove the fingerboard pickup from the body or from the pickguard.
- 2) It is necessary to remove the bridge from the instrument to remove the bridge pickup. Unscrew the 4 large wood screws holding the bridge to the body and remove the pickup from the bridge.

Mounting the Fingerboard Pickup:

Refer to Diagrams #1 or #2

- 1) First, make sure the fingerboard pickup fits in the cutout of the pickguard. It may be necessary to enlarge the pickup cutout.
- 2) Attach the pickup cable as shown in Diagram #2 then either;
 - a) Mount the Fingerboard pickup by attaching it to the body with the #3 x 1" wood screws included as in Diagram #1 or,
 - b) Mount the pickup to the pickguard using the #5 x 1" machine screws and springs included, the pickup adjustment tabs are pre-threaded for the #5 screws as in Diagram #2.

Don't worry about the pickup height adjustment at this time, it will be adjusted later.

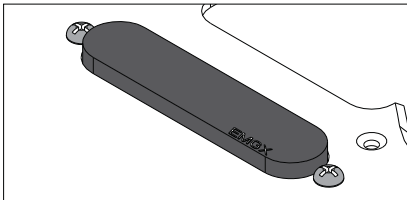

Mounting the Bridge Pickup:

Refer to Diagrams 3 and #4

- 1) As mentioned earlier, it is necessary to remove the bridge in order to replace the pickup. This is easily done by unscrewing the 4 screws that hold the bridge to the body. After removing the bridge, simply replace the pickup using the three 6/32 screws and the conical springs provided. Plug on the pickup cable to the back of the pickup as shown in Diagram #3 and route the cable into the control cavity. Diagram #4 shows a top view of the installed pickup in the bridge.

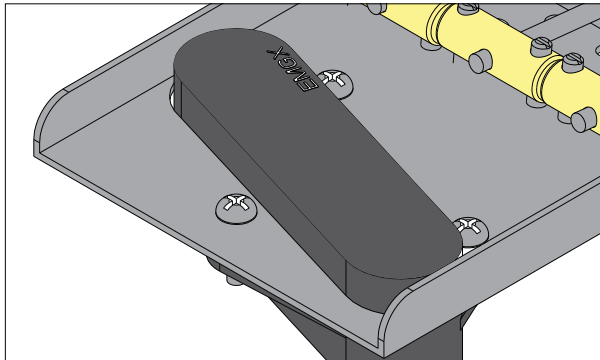

****Tips and Tricks****

Start your installation by:

- 1) Read the Installation Notes on Page 1 if you haven't already and determine if you have the right output jack for your instrument. A Stereo 12B type (Included) or a 152B Long Panel Jack will be required. Also, make sure a 9 Volt battery will fit in the control compartment.
- 2) Remove the strings
- 3) Remove any existing Pickups and controls (remember the order and function of each control)
- 4) Install the EMG Volume and Tone Controls and tighten them in.
- 5) Then install the pickups keeping any excess cable under the pickup rather than in the control cavity.

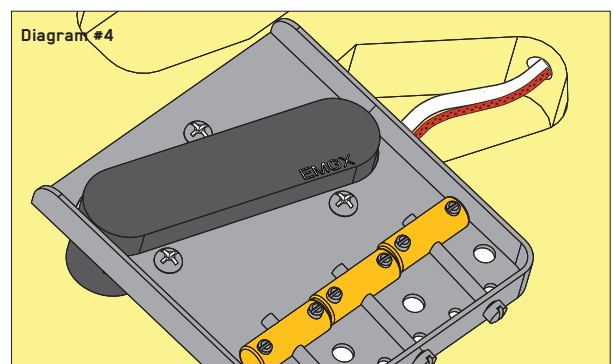
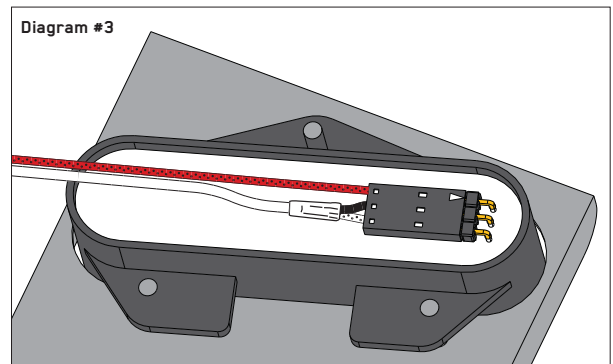
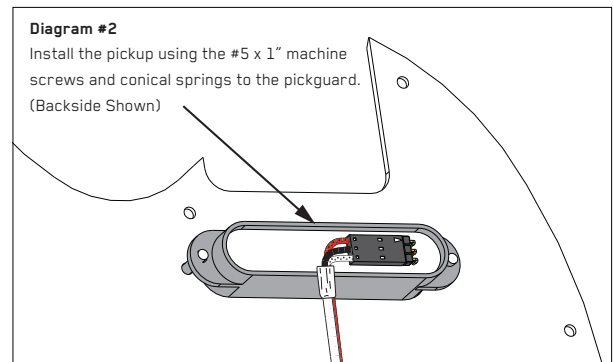
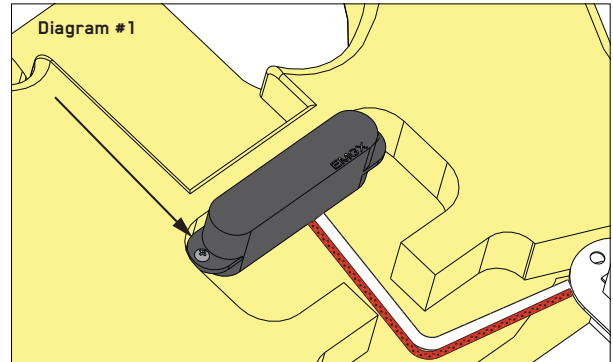

Installation Instructions:

EMG Models: T-X & TC-X SET

Alternate diagrams:

The diagrams shown here all use the B162 (T3) switch that is designed for Fender Telecaster*. When the switch is mounted to the Tele control plate the Bridge and Neck Pickup input legend will be as it says on the PC Board. If you use the B162 for another type of guitar, you might have the PC Board facing the other direction. If this is so, simply reverse the inputs. Use the BRG input for the Neck Pickup, and use the NEK input for the Bridge Pickup.

Diagram #10

This diagram shows the wiring for the standard installation included in these instructions.

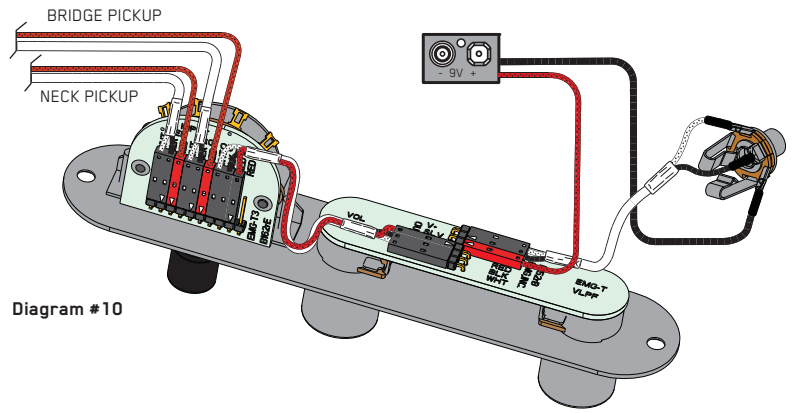

Diagram #10

Diagram #11

This diagram shows the wiring of an EMG-X using discrete controls. The tone control could be any EMG Active control, like the SPC, RPC, EXG, VLPF, or even a BT Control. This installation would be similar to an EMG-X installation using the VLPF Active tone control.

Diagram #11

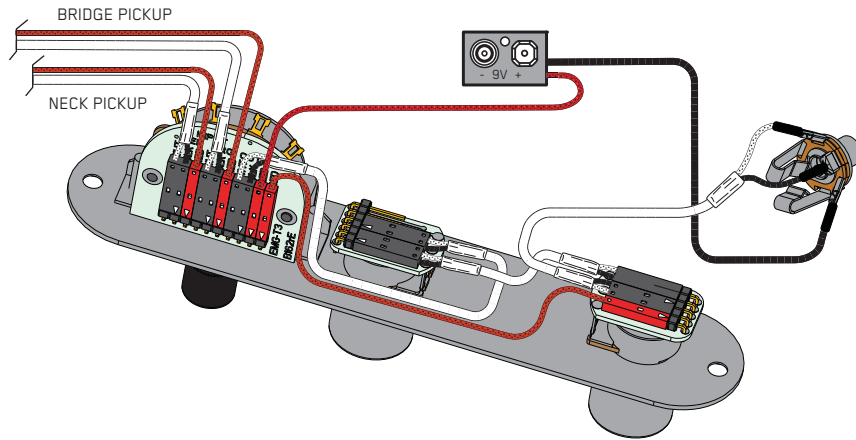

Diagram #12

If the instrument has a Battery Holder:

If your instrument has a 9 or 18-Volt battery holder you can still use the EMG Connectors to supply power to the pickups. Simply cut and strip the wires from the battery clip provided. Twist the wires together (Red to Red and Black to Black) and use the shrink tubing included to cover the connections. Soldering the wires is recommended.

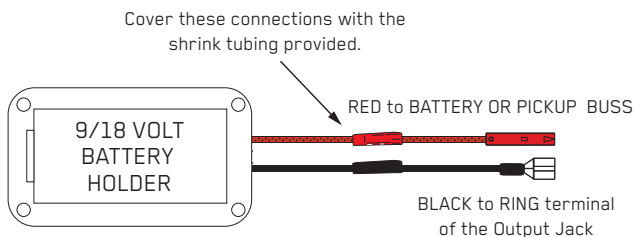

Diagram #13

Soldering to the 152B Panel Jack:

If your instrument has a long Panel Jack like the one below you will have to solder the output cable as shown. Ground (Black) to the Sleeve
Signal (White) to the Tip
Battery Negative (Black) to the Ring

