

0230-0123C

PO BOX 4394
SANTA ROSA, CA
95402 USA

P (707) 525-9941
F (707) 575-7046
EMGPICKUPS.COM

X-SERIES

INSTALLATION INFORMATION EMG MODELS: **JV-X SET (4-STRING)**

SPECIFICATIONS:

Logo Color
Magnet Type *
Resonant Frequency (KHz)
Output Voltage (String)
Output Voltage (Thump)
Output Noise (60 Hz)
Output Impedance (Kohm)
Current @9V (Microamps)
Battery Life (Hours)
Maximum Supply (Volts DC)

MODEL:

JV-X
Silver
A
3.20
2.00
8.00
-99
2.00
80
3000
27

*Note: Magnet Type: A (Alnico)

PICKUP AND MAGNET DIMENSIONS:

The EMG JV-X Set has the housing dimensions shown above. The shorter housing (SJ) is for the neck pickup, while the longer housing (LJ) is for the bridge pickup. Each of the housings have different magnet layouts as well as mounting hole distances.

IMPORTANT INSTALLATION NOTES:

- 1) Only one 9-Volt battery is required to power the pickups and any accessories such as the EXB, BTC, B125 Blend, and BQ Controls. Use an Alkaline or Lithium battery for longest life.
- 2) The Volume and Tone controls included with this EMG System are 25K Ohm. This value is required for the system to work correctly.
- 3) A stereo output jack (12B) is included with the EMG Pickups; it grounds the black battery wire to turn on the pickups when the plug is inserted into the jack. If you are replacing passive pickups, make sure to use the jack included. If your guitar has a long panel jack (see Page 2, bottom), make sure it is a stereo type, a Switchcraft 152B is recommended.
- 4) When installing EMG Active Pickups, DO NOT connect the bridge ground wire. This wire is usually soldered to a volume or tone control casing and goes to the bridge. This wire grounds the strings and uses them and your body as a shield against hum and buzz. It also creates a shock hazard.

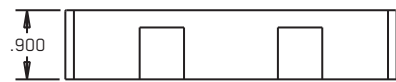
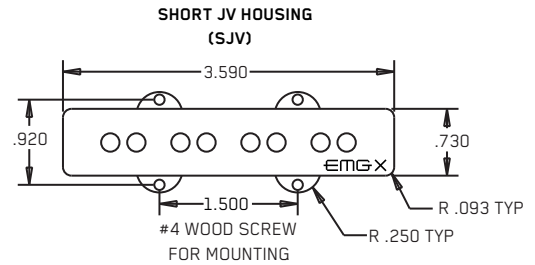
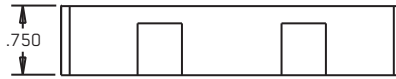
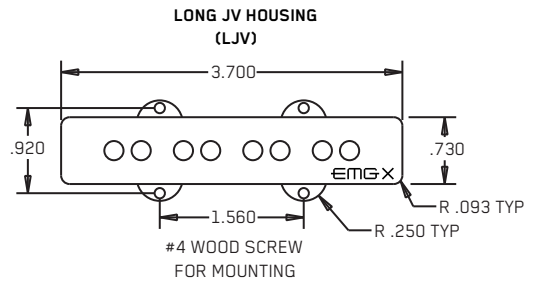

EMG Pickups are shielded internally and DO NOT require string grounding. This greatly reduces the possibility of reverse polarity shock from microphones and other equipment.

- 5) EMG Active Pickups have very little magnetism compared to passive pickups. We recommend you adjust the pickups as close to the strings as possible. Sustain and string movement will not be inhibited by close adjustment.
- 6) If your installation is different from the diagrams in these instructions or you need additional diagrams visit our website: emgpickups.com for a complete listing of available diagrams.

7) SPECIAL NOTE:

The diagrams shown are for EMG Active Pickups. All diagrams show the Red Wire coming from the pickups connected to the battery. If you are installing EMG-HZ Passive Pickups refer to their diagrams. The Red Wire of the HZ Pickup is NOT for battery power, it is a coil wire.

WARRANTY

All EMG Pickups and accessories are warranted for a period of two years. This warranty does not cover failure due to improper installation, abuse or damage. If upon examination the pickup is determined to be defective, a replacement will be made. Warranty replacement products are covered by this same warranty. This warranty covers only those pickups and accessories sold by authorized EMG Dealers. This warranty is not transferable.

Installation Instructions:

EMG Models: JV-X SET (4-STRING)

General Notes:

- Every attempt has been made to make this a solderless installation. There are some instances where this is not possible;
- 1) If your instrument uses the long panel output jack and you had passive pickups you will need a new stereo output jack, the Switchcraft 152B is recommended. Soldering to the new jack will be required, see page 3.
 - 2) Power Supply tips are on page 4. If your instrument has a battery holder, you are installing this pickup with an older EMG, or you want to supply your instrument with +18 Volts, see page 4 for tips to avoid soldering.

******Tips and Tricks******

Start your installation by:

- 1) Read the General Notes on Page 2 if you haven't already and determine if you have the right output jack for your instrument. A Stereo 152B type (Included) or a 152B Long Panel Jack will be required.
- 2) Remove the strings
- 3) Remove any existing Pickups and controls (remember the order and function of each control)
- 4) Install the EMG Volume and Tone Controls and tighten them in.
- 5) Then install the pickups keeping any excess cable under the pickup rather than in the control cavity.

Installation Instructions:

EMG Model: JV-X SET(4-STRING)

2 Pickups, 2 Volume controls, VLPF Active Master Tone, no selection switch

J-Bass Style wiring

Refer to Diagram #2

- 1) Install the Pickups and route the Pickup cables to the control cavity. If the cables are too long, keep any excess under the pickup.
- 2) Mount the Volume and Tone controls into the body / pickguard. Plug the Neck Pickup Cable onto the Neck Volume control. Plug the Bridge Pickup Cable onto the Bridge Volume control.
- 3) Plug a coax cable from the Neck Volume control to the Bridge Volume control.
- 4) Plug a coax cable from the Bridge Volume control the VLPF Master Tone control.
- 5) Plug the output cable from the VLPF Master Tone control and connect the output wires to the output jack by pushing the connectors on as shown. WHITE wire onto the TIP (T) contact, BLACK wire onto the SLEEVE (S) contact, BLACK Battery Negative wire onto the RING (R) contact.
- 6) Plug the RED Wires of the pickups onto the V+ Supply Buss (RED Shroud) along with the RED of the battery clip. Extra pins on the V+ Supply Buss are for EMG Accessories.
- 7) Put the battery in the insulating foam piece provided and place it securely in the control cavity. We suggest that you plug in the instrument and test it before closing the control cavity.

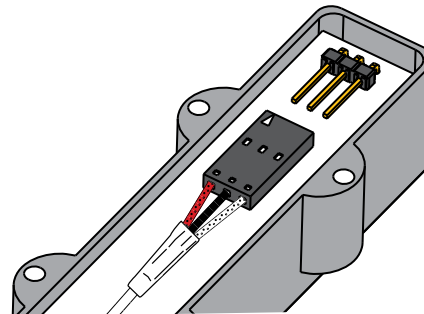

Diagram #1

Insert the plug onto the 3 pin header of the pickup as shown above. Note the orientation arrow.

Diagram #2

Volume / Volume Master Tone (Passive)

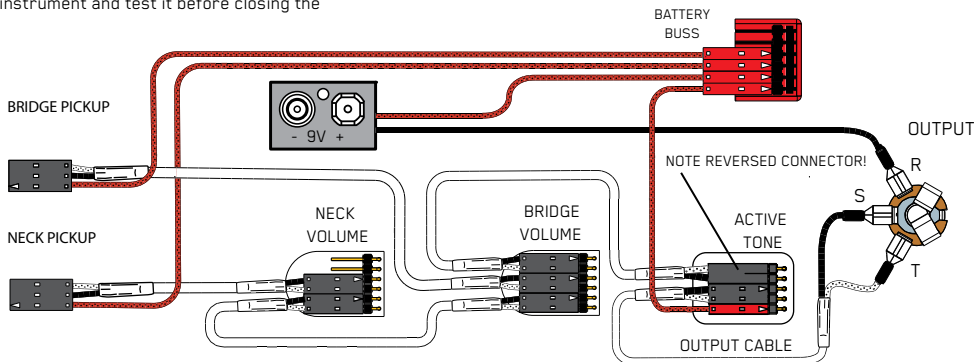

Diagram #3

B118 Active Balance Control Active Tone / Master Volume

This installation can be used for instruments with 3 control positions like the diagram above, but use a Balance control instead of 2 Volume controls. The VLPF Active Tone Control shown in this diagram can be replaced with the EMG-EXB Expander, EMG-BTC Control (Active Bass and Treble EQ) or the VMC.

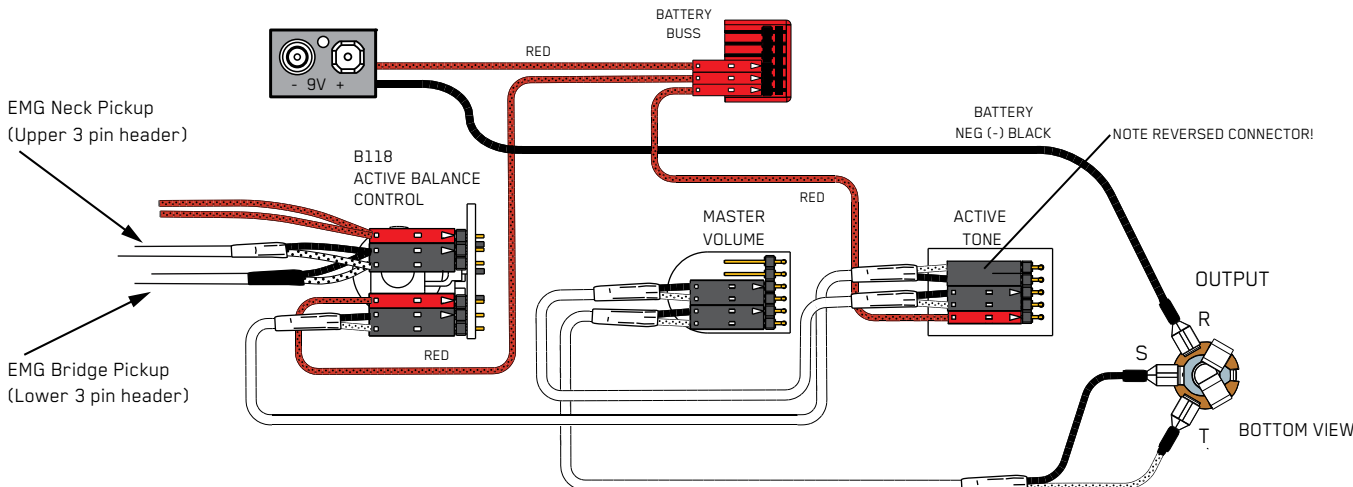
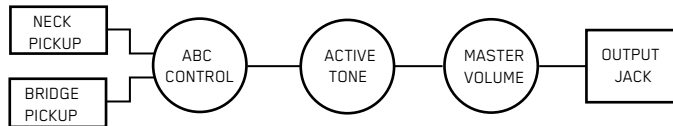

Diagram #4

Soldering to the 152B Panel Jack:

If your instrument has a long Panel Jack like the one below you will have to solder the output cable as shown.

- Ground (Black) to the sleeve
- Signal (White) to the Tip
- Battery Negative (Black) to the Ring

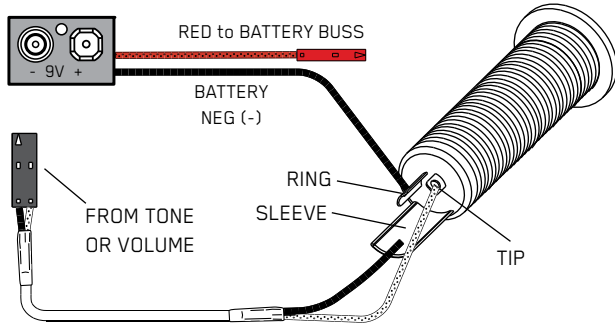
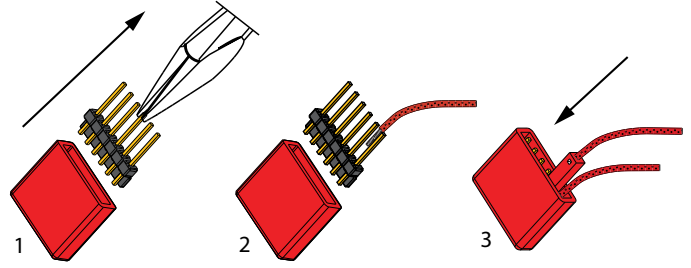

Diagram #5

Soldering to the battery buss:

If your instrument has an older EMG Pickup you can solder the pickup RED wire to the buss. Simply use some needle nose pliers, pull out the V+ header and solder the RED Wire from the pickup(s) to any of the pins and then re-insert the header into the housing.



Installation Instructions:

EMG Models: EMG-JV-X SET (4-STRING)

Installation (Two Pickup Guitars with Selection switch):

Guitars with two pickups and a selection switch will use the EMG B157 Pickup Buss shown at the right in Diagram #6a.

The Pickup Buss is a convenient way to wire your guitar without soldering.

There is a separate sheet attached to these instructions that describes the Pickup Buss in detail.

In all installations it's best to find a place to mount the Pickup Buss in the control cavity before starting. Then, after the cables are routed use the velcro to mount it securely.

2 Pickups / Toggle Select Switch / Master Volume and Tone

- 1) Install the Pickups and route the Pickup cables to the control cavity. If the cables are too long, wind up the excess and keep it under the pickup.
- 2) Mount the Volume and Tone controls into the body. Plug both Pickup cables into the Pickup Buss (BLACK Shroud) as shown, Refer to Diagram #6a. Bridge Pickup to Position 1. Neck Pickup to Position 2.
- 3) Plug a coax cable from the Pickup Buss (Position 3) to the Master Tone (Active) as shown in Diagram #6b. Note the reversed connector on pins 1 and 2.
- 4) Plug a coax cable from the Master Tone (ACTIVE) to the Master Volume as shown.
- 5) Strip the insulation from the switch wires and Insert them into the GREEN Terminal Block and tighten the screws with a small screwdriver. The Bridge pickup goes to the BR Terminal. The Neck pickup goes to the NK Terminal. The Output of the switch goes to the O Terminal. If there is a ground wire coming from the switch, insert it into one of the black terminals on the terminal block.
- 6) Plug the output cable onto the Master Volume control and connect the output wires to the output jack and push the connectors onto the jack as shown. WHITE wire onto the TIP (T) contact, BLACK wire onto the SLEEVE (S) contact, BLACK Battery Negative wire onto the RING (R) contact.

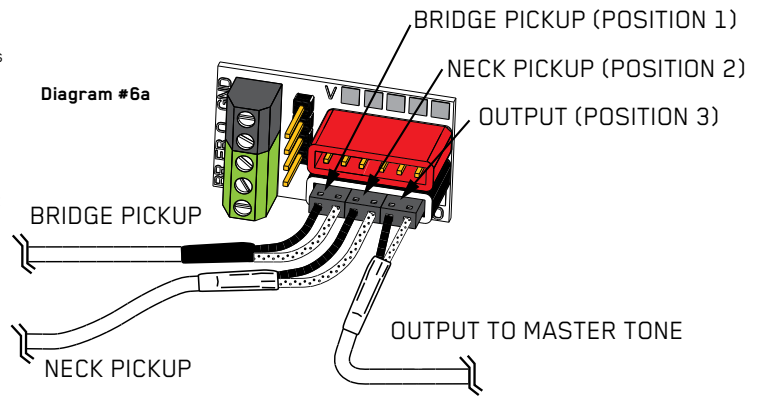

- 7) Plug the RED Wires of the pickups onto the V+ Supply Buss (RED Shroud) along with the RED of the battery clip, and the RED wire of the Active Tone Control. Extra pins on the V+ Supply Buss are for EMG Accessories.
- 8) Put the battery in the insulating foam piece provided and place it securely in the control cavity. We suggest that you plug in the instrument and test it before closing the control cavity.

Diagram #6b

2 Pickups
Toggle Style Select Switch
Master Volume & Master Tone

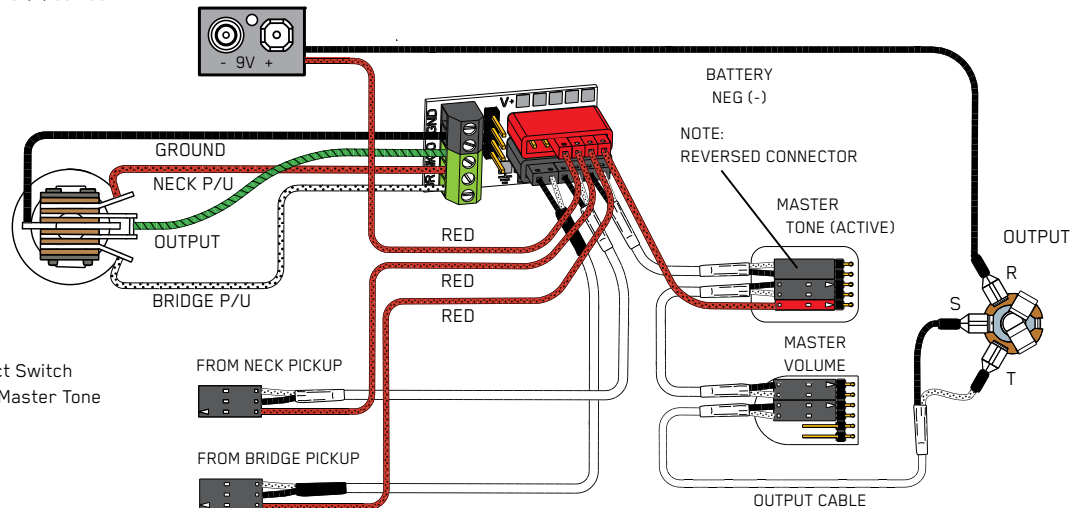

Refer to Diagram #7

- 1) Install the Pickups and route the cables to the control cavity.
If the cables are too long, wind up the excess and keep it under the pickup.
- 2) Mount the Volume and Tone controls into the body.
Plug both Neck and Bridge pickup cables onto the Volume Controls as shown.
- 3) Plug a coax cable from the Bridge (BR) Active Tone to Position #1 on the Pickup Buss.
Note the reversed connector on pins 1 and 2.
- 4) Plug a coax cable from the Neck (NK) Volume control to the (NK) Active Tone Control. Note the reversed connector on pins 1 and 2.
- 5) Plug a coax cable from the the (BR) Active Tone to Position #1 on the Pickup Buss.
- 6) Plug a coax cable from the the (NK) Active Tone to Position #2 on the Pickup Buss.
- 7) Strip the insulation from the switch wires and Insert them into the GREEN Terminal Block and tighten the screws with a small screwdriver.
The Bridge pickup goes to the BR Terminal
The Neck pickup goes to the NK Terminal
The Output of the switch goes to the O Terminal
If there is a ground wire coming from the switch, insert it into one of the black terminals on the terminal block.

- 8) Plug the output cable from the Pickup Buss (Position 3) to the output jack and push the connectors onto the jack as shown.
WHITE wire onto the TIP (T) contact,
BLACK wire onto the SLEEVE (S) contact
BLACK Battery Negative wire onto the RING (R) contact.
- 9) Plug the RED Wires of the pickups onto the V+ Supply Buss (RED Shroud) along with the RED of the battery clip, and the RED wires from the Active Tone Controls.
- 10) Put the battery in the insulating foam piece provided and place it securely in the control cavity.
We suggest that you plug in the instrument and test it before closing the control cavity.

Diagram #7

- 2 Pickups
- 2 Volume (either volume will act as a master)
- 2 Tone
- Toggle Style Switch

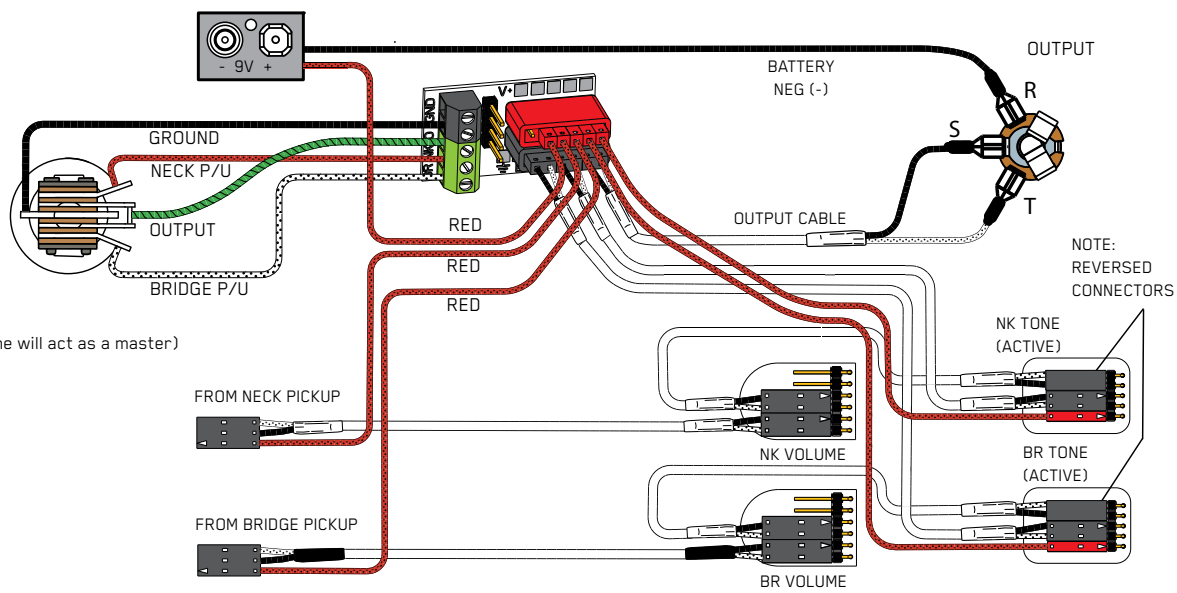

Diagram #8

If the instrument has a Battery Holder:

If your instrument has a 9 or 18 Volt battery holder you can still use the EMG Connectors to supply power to the pickups. Simply cut and strip the wires from the battery clip provided. Twist the wires together (Red to Red and Black to Black) and use the shrink tubing included to cover the connections. Soldering the wires is recommended.

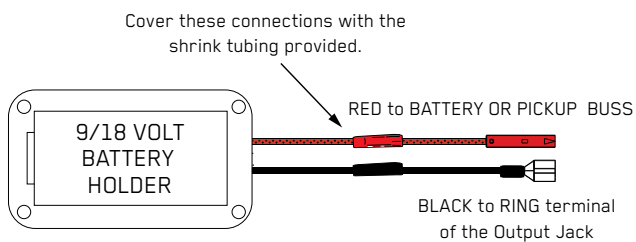

Diagram #9

+18 Volt Wiring Option:

If you want to operate your instrument at +18 Volts for more headroom then use 2 batteries wired as below. Also, if you are using any type of EQ in your instrument (EMG-BT, BQ) or anything that boosts the pickup signal then +18 Volts is recommended.

