



0230-0155B

PO BOX 4394
SANTA ROSA, CA
95402 USA

P (707) 525-9941
F (707) 575-7046
EMGPICKUPS.COM

INSTALLATION INFORMATION EMG MODELS: S/S/S COMBINATION SYSTEMS

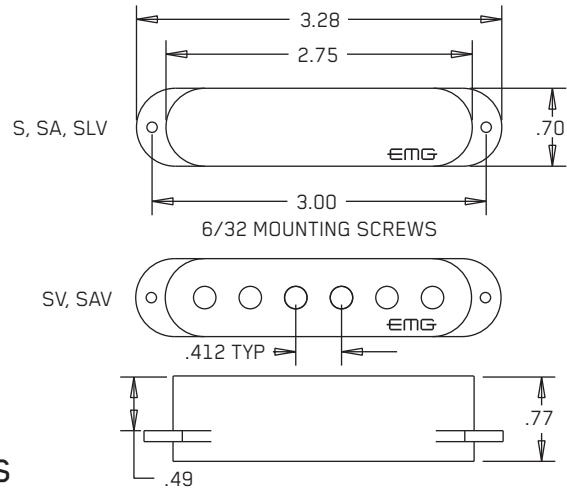

SPECIFICATIONS:

	MODEL:				
	S	SA	SV	SAV	SLV
Logo Color	Silver	Gold	Gold	Gold	Gold
Magnet Type *	C	A	A	A	A
Resonant Frequency (KHz)	4.05	3.70	2.41	4.41	3.33
Output Voltage (String)	1.00	1.00	1.00	1.00	1.00
Output Voltage (Strum)	3.00	3.00	3.00	3.00	3.00
Output Noise (60 Hz)	-101	-101	-102	-101	-103
Output Impedance (Kohm)	10	10	10	10	10
Current @9V (Microamps)**	240	240	690	240	240
Battery Life (Hours)**	1000	1000	400	1000	1000
Maximum Supply (Volts DC)	27	27	27	27	27

*Note: Magnet Type: A (Alnico) C (Ceramic)

**Note: Specifications shown are for the entire 3 pickup system

INSTALLATION NOTES:

All EMG Pickups are compatible with each other. The connector system is an easy method of installation, avoiding the need to solder. Older systems may need to be soldered, while the newer systems can be easily connected and modified. If you have an older EMG Pickup you can install the new system along with it.

EMG accessories like the VLPF, EXG, SPC or RPC Controls can be added to any EMG Pickup System without the need for an extra battery.

IMPORTANT INSTALLATION NOTES:

- 1) Only one 9-Volt battery is required to power the pickups and any accessories such as the SPC, RPC, EXG, AB, PA-2, and Pi-2. Use an Alkaline or Lithium battery for longest life.
- 2) The Volume and Tone controls included with this EMG System are 25K Ohm. This value is required for the system to work correctly.
- 3) A stereo output jack (12B) is included with the EMG Pickups; it grounds the black battery wire to turn on the pickups when the plug is inserted into the jack. If you are replacing passive pickups, make sure to use the jack included. If your guitar has a long panel jack make sure it is a stereo type, a Switchcraft 152B is recommended.
- 4) When installing EMG Active Pickups, DO NOT connect the bridge ground wire. This wire is usually soldered to a volume or tone control casing and goes to the bridge. This wire grounds the strings and uses them and your body as a shield against hum and buzz. It also creates a shock hazard.

EMG Pickups are shielded internally and DO NOT require string grounding. This greatly reduces the possibility of reverse polarity shock from microphones and other equipment.

- 5) EMG Active Pickups have very little magnetism compared to passive pickups. We recommend you adjust the pickups as close to the strings as possible. Sustain and string movement will not be inhibited by close adjustment. Models EMG-SV, EMG-SAV, and EMG-SLV feature magnetic pole pieces which can inhibit intonation and string movement.
- 6) If your installation is different from the diagrams in these instructions or you need additional diagrams visit our website: emgpickups.com for a complete listing of available diagrams.

WARRANTY

All EMG Pickups and accessories are warranted for a period of two years. This warranty does not cover failure due to improper installation, abuse or damage. If upon examination the pickup is determined to be defective, a replacement will be made. Warranty replacement products are covered by this same warranty. This warranty covers only those pickups and accessories sold by authorized EMG Dealers. This warranty is not transferable.

Installation Instructions:
EMG-S/S/S Combination Systems

General Notes:

- Every attempt has been made to make this a solderless installation. There are some instances where this is not possible;
- 1) If your instrument uses the long panel output jack and you had passive pickups you will need a new stereo output jack, the Switchcraft 152B is recommended. Soldering to the new jack will be required, see the Power Tips Data sheet at <http://www.emgpickups.com>.
 - 2) Some instruments may already have a battery holder installed and in that case soldering may be required, see page 3.

Installing EMG Combination Systems is very easy and is accomplished in a few steps. The controls included have a 10 mm bushing height so they can be used either on a pickguard, or body mount. The cable lengths are designed for a pickguard, so you should make sure they are long enough if you are mounting the system into a body. Longer cable lengths may be required.

Step One:

Mount the pickups onto the Pickguard, or in the guitar body.

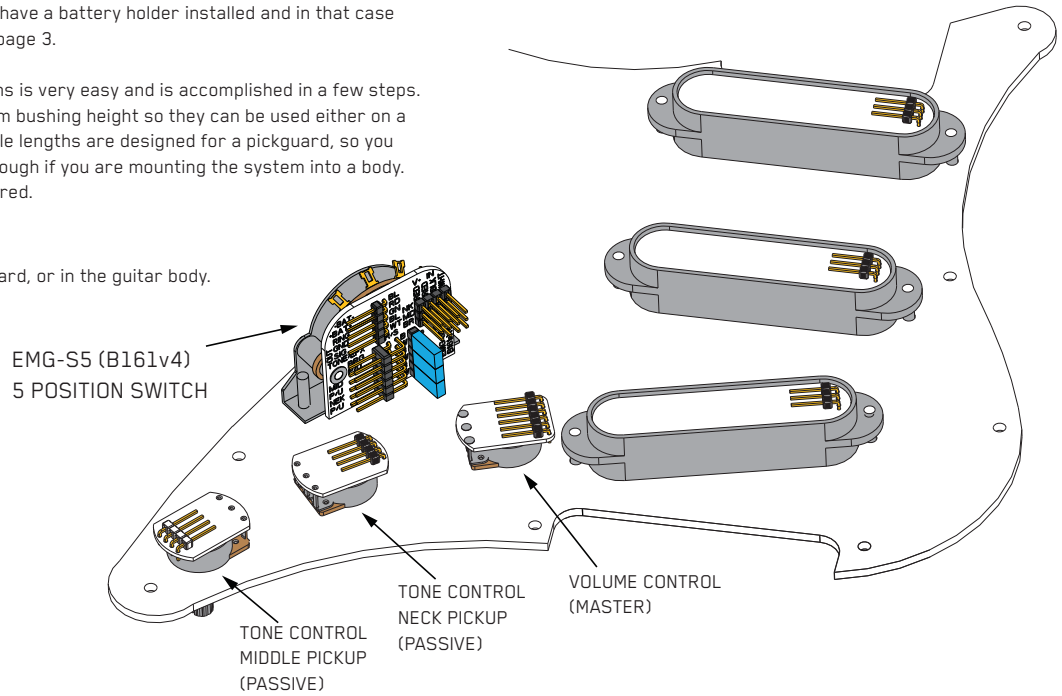

Step Two:

Plug the pickup cables onto the pickups and then onto the switch as shown.

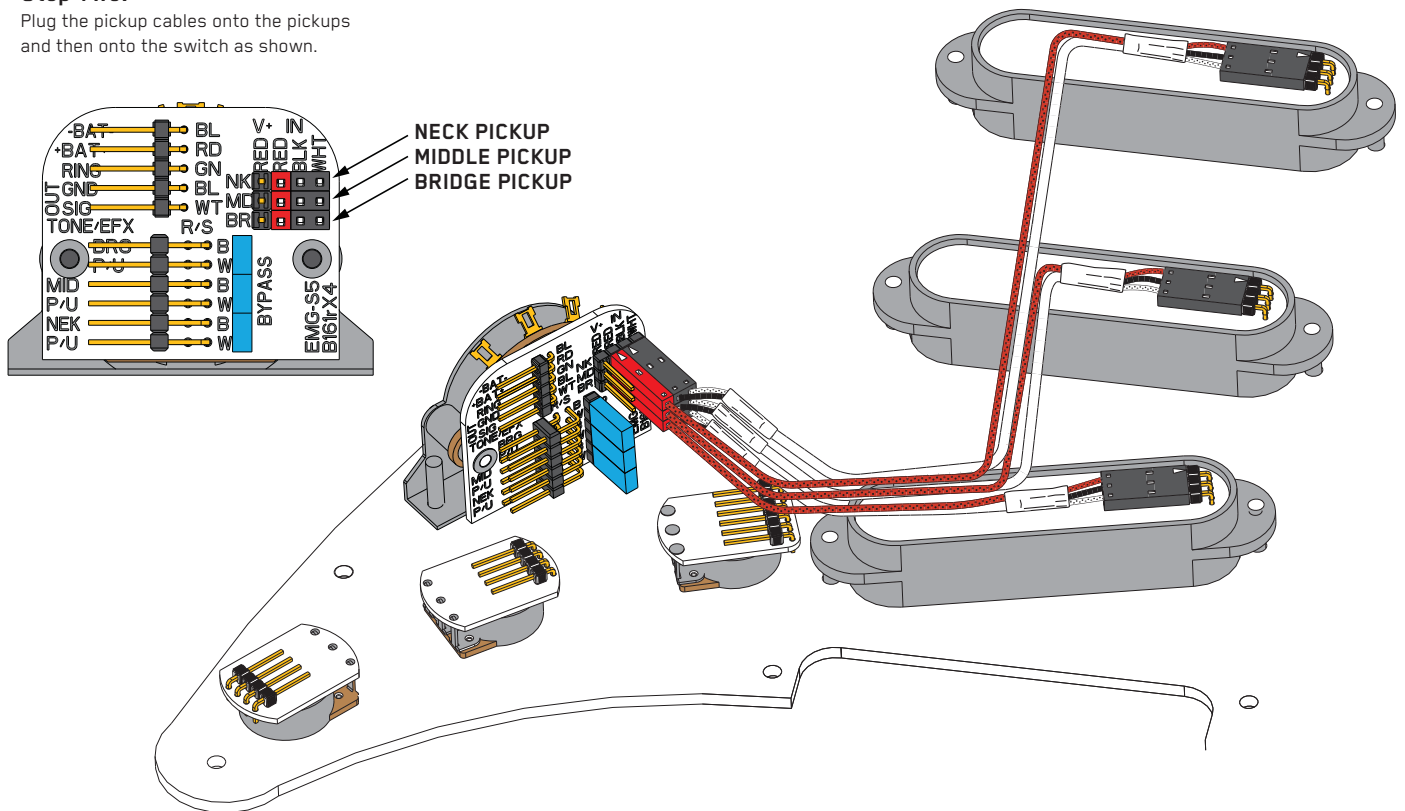

Step Three:

Plug the Volume and Tone control cables onto the controls and then onto the switch as shown.

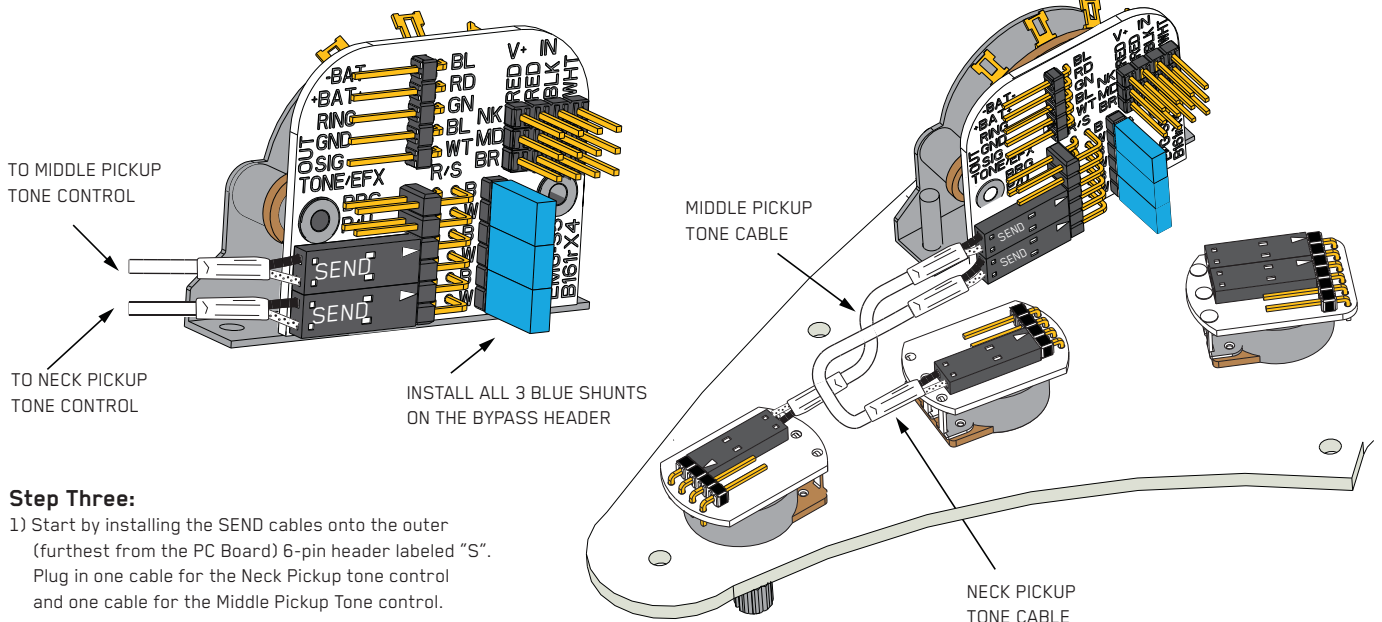

Step Three:

1) Start by installing the SEND cables onto the outer (furthest from the PC Board) 6-pin header labeled "S". Plug in one cable for the Neck Pickup tone control and one cable for the Middle Pickup Tone control.

Step Four:

The Pickguard is now fully assembled. Next the pre-wired output jack needs to be mounted in the Jack plate. Mount the Jack onto the plate with the orientation as shown with the Tip spring pointing down. Refer to the diagrams below and make sure the Jack is mounted tightly.

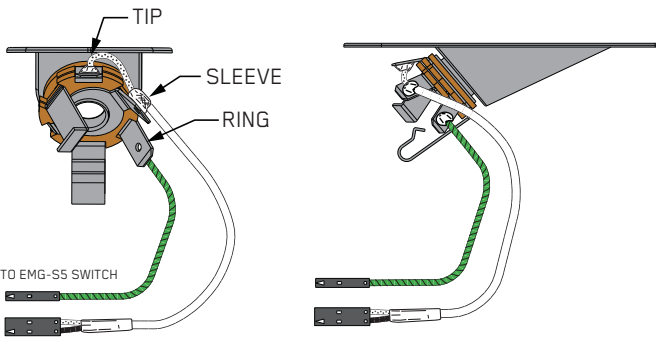

If the instrument has a Battery Holder:

If your instrument has a 9 or 18-Volt battery holder you can still use the EMG Connectors to supply power to the pickups. Simply cut and strip the wires from the battery clip provided. Twist the wires together and use the shrink tubing included to cover the connections. Soldering the wires is the preferred.

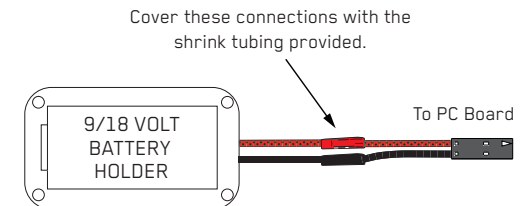

Step Five:

Route the Output cable from the Jack cavity into the control cavity via the small hole. If the hole is too small, Push the connectors through one at a time. Fasten the Jack plate onto the guitar and test to make sure the cable inserts and exits easily.

Mount the battery in the control compartment. Insulate the battery using the foam insulator provided..

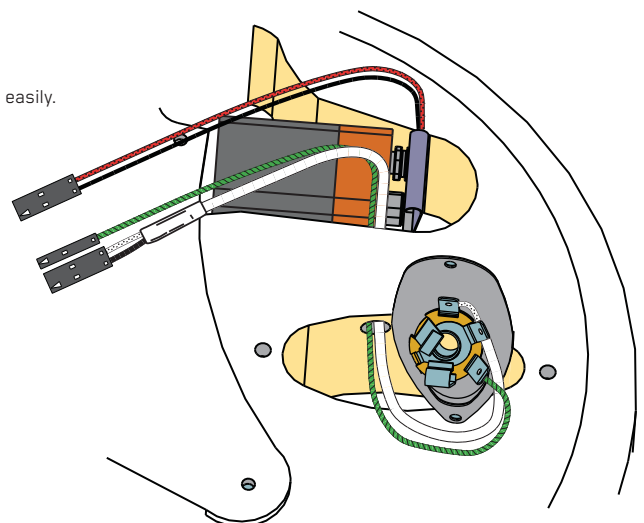

Step Six:

- 1) Plug the Output Cable from the PC Board (GND/SIG) to the Volume Control.
- 2) Plug the Output cable from the Output Jack onto the Volume control as shown.
- 3) Plug the green wire onto the Ring terminal pin of the Switch PC Board.

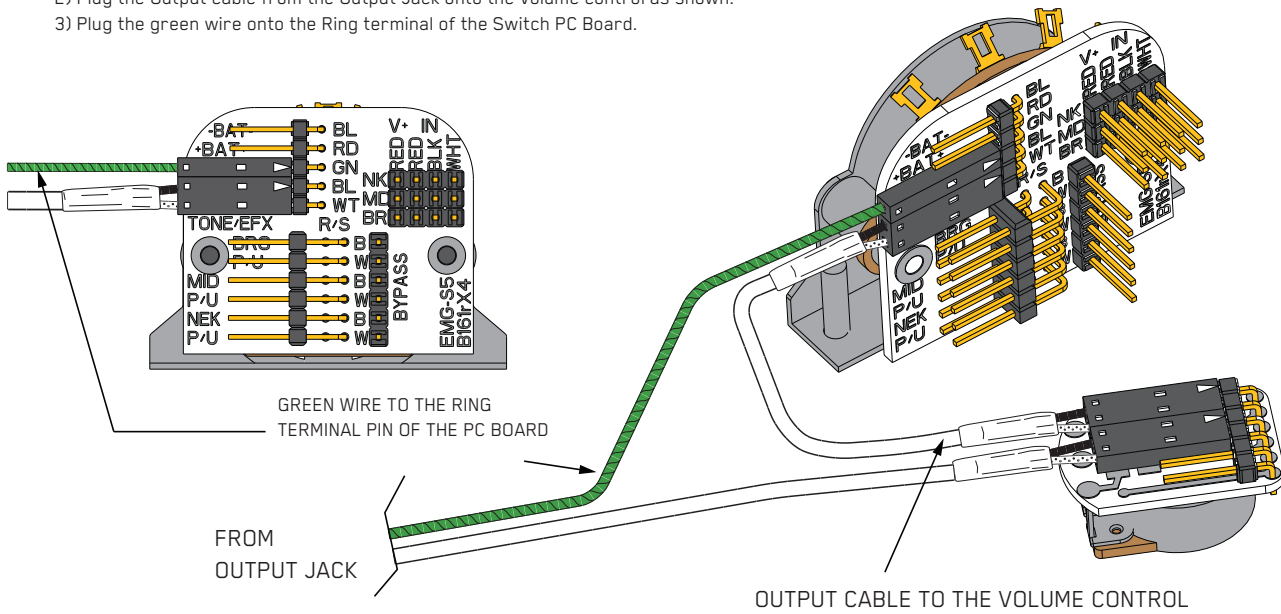

Step Seven:

Plug the Battery clip cable onto the BAT- (BLACK) and the BAT+ (RED) terminals of the PC Board.

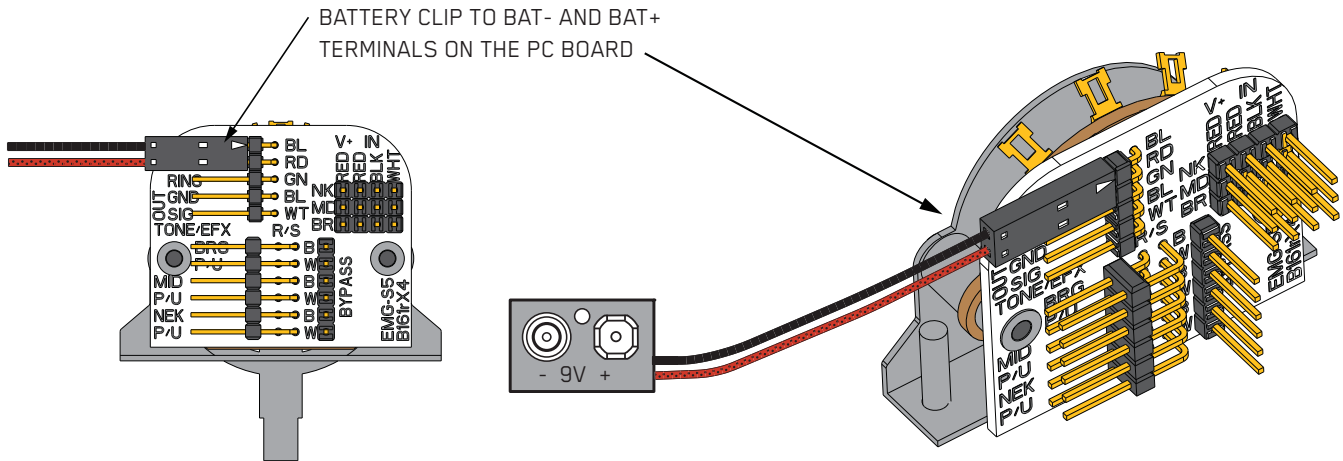

Step Eight:

This completes the installation. Plug the battery clip onto the battery. We suggest you plug in the instrument, tap lightly on the pickups with a small screwdriver to make sure the pickups are working correctly. When the battery needs to be replaced (about 6 months to 1 year) refer to the diagram at the right.

Battery Replacement:
Remove these 4 screws,
gently lift the pickguard'
remove and replace the battery.

