

0230-0269A

PO BOX 4394  
SANTA ROSA, CA  
95402 USA

P (707) 525-9941  
F (707) 575-7046  
EMGPICKUPS.COM

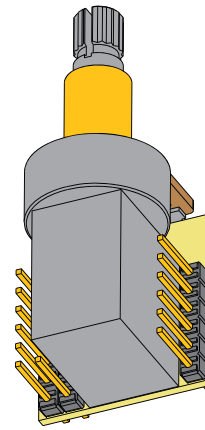

## INSTALLATION INFORMATION EMG MODEL: B136RE PUSH-PULL POT FOR EMG-89 AND ACTIVE EMG-TW PICKUPS

### GENERAL INFORMATION:

The EMG B136rE is a Push-Pull Switch (DPDT) combined with a 25K Pot onto a split shaft control. The Push-Pull switch provides a convenient way to choose either Single-Coil or Dual-Coil sounds from Active EMG-TW Style Pickups. The 25K Pot can be used as a Volume or Tone Control for the pickup, or it can be used as a Master Volume or Master Tone Control for the instrument. The B136 uses EMG's standard solderless installation system. The B136 version described in this data sheet is the "E" Version that allows daisy-chaining of volume controls without any extra connectors.

### The B136 has 2 Sections.

#### Section 1) Push-Pull Switch:

This is the single in-line 6 pin header.  
This header is for the pickup input.

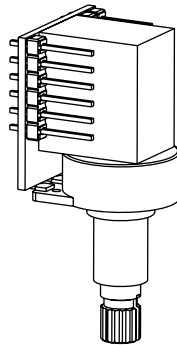

#### Dimensions: B136rE Push-Pull Pot

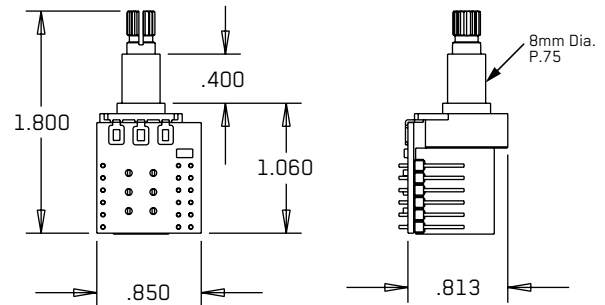

#### Section 2) 25K Audio Taper pot:

The dual-header labeled H1 thru H6 directs how the pot functions.

The Pot can be used in 4 different ways:

- 1) Volume Control for the pickup only
- 2) Tone Control for the pickup only
- 3) Master Volume Control for the entire instrument
- 4) Master Tone Control for the entire instrument

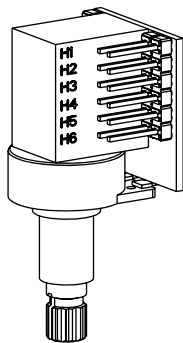

#### B136E SCHEMATIC

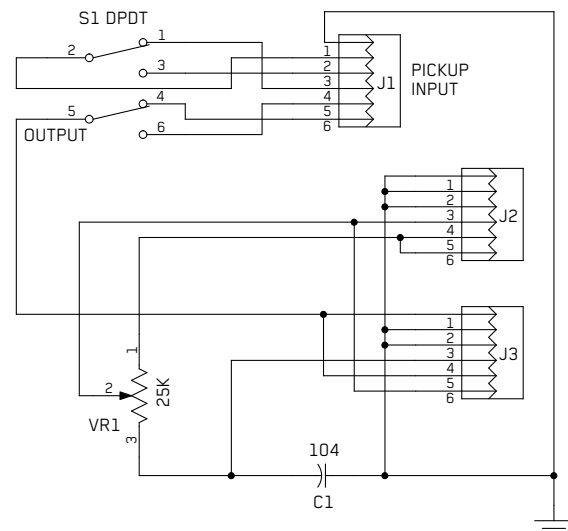

#### Using the B136 with EMG-X Series Pickups:

The Tone Control for the B136 is passive. It is not suitable for EMG-X Series Pickups. If you are using the B136 with EMG X-Series Pickups it should be used as a Volume Control only, either for the Pickup or as a Master Volume.

**Installation Instructions:**  
**EMG B136rE**

**Using the Push-Pull Switch Section (DPDT)**

Refer to Diagrams #1 and #2

The push-pull switch section (DPDT) lets you choose between the single-coil sound and a dual-coil sound by pulling or pushing the pot shaft up or down. You have the option of having the single-coil sound in either the up or down position and vice-versa for the dual-coil sound. Diagrams #1 and #2 show how to connect the TW Pickup cable to choose either option. Select the diagram that suits you and push the cable connectors onto the single line 6-pin header. Simply turn over cable connectors 1 and 2 changing the wire order to choose between the two options. Connector 3 remains the same for either choice.

**Diagram #7**

Insert the plug onto the 7 pin header of the pickup as shown above. Note the orientation arrow.

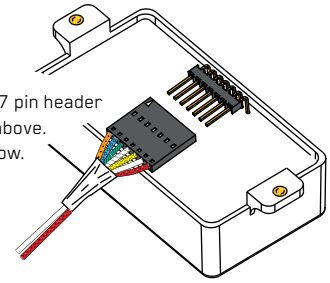

**Diagram #1**

HUMBUCKING ON: DOWN POSITION  
 SINGLE COIL ON: UP POSITION

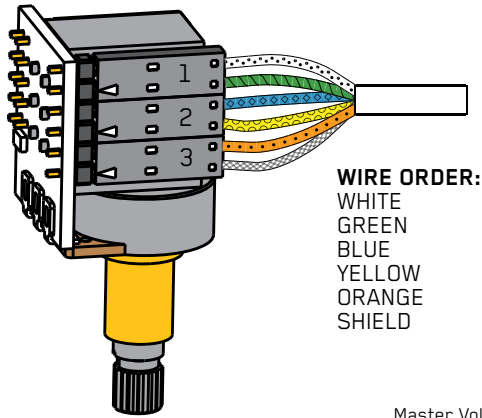

Master Volume control for the instrument

**Diagram #2**

SINGLE-COIL ON: DOWN POSITION  
 HUMBUCKING ON: UP POSITION

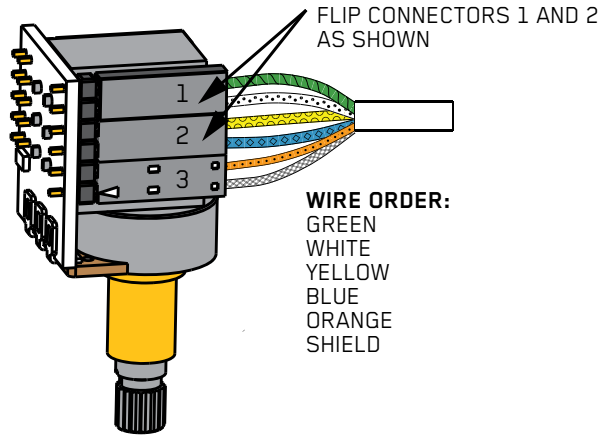

**Using the Push-Pull Pot Section**

On the PC Board there is a dual-line header with 6 pairs of pins. They are listed on the PC Board as H1 through H6. By using the the connections shown in Diagrams #3 through #6, you can choose any of the 4 options.

- 1) Volume control for the Pickup (diagram #3)
- 2) Tone control for the Pickup(diagram #4)
- 3) Master Volume control for the instrument(diagram #5)
- 4) Master Tone control for the instrument (diagram #6)

**Using the Pot Section as:**

**1) The Pickup Volume control.**

Refer to Diagram #3

Use Diagram #3 if you have a single TW Pickup installed in your instrument, or have two or more pickups in your instrument and want to use the pot as the Volume control for the TW Pickup only. Install the shunts on positions H4 and H6. The output of the 25K Pot can be either header H1 or H2.

**Diagram #3**

PUSH-PULL POT USED AS THE PICKUP VOLUME CONTROL

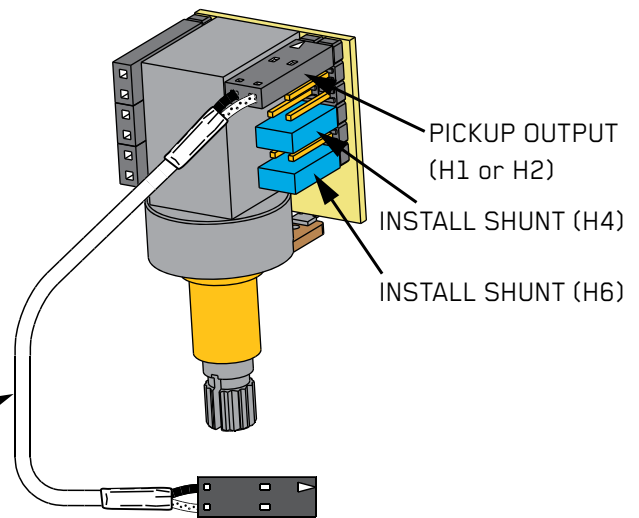

PICKUP OUTPUT:  
 TO TONE CONTROL OR  
 SELECTION SWITCH OR BUSS  
 FOR 2 OR 3 PICKUP GUITARS

OR; TO THE OUTPUT JACK IN SINGLE  
 PICKUP GUITARS WITH NO TONE  
 CONTROL

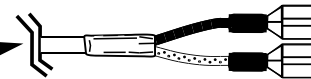

**Diagram #4**  
 PUSH-PULL POT USED AS  
 THE PICKUP TONE CONTROL

**Using the Pot Section as:**

**A Tone control for the TW Pickup.**

Refer to diagram #4 if you want to use the 25K pot as a tone control for only the TW Pickup.

Install a shunt on position H4.

The output of the pickup can come from either H1 or H2.

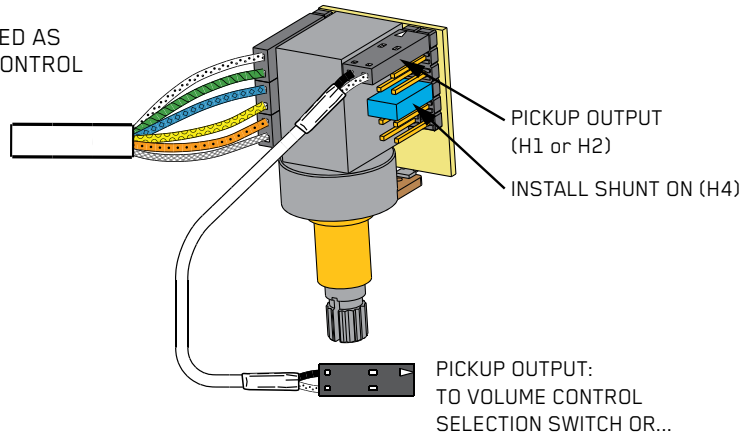

**Diagram #5**  
 PUSH-PULL POT USED AS  
 THE MASTER VOLUME CONTROL

**Using the Pot Section as:**

**A Master Volume control for the Instrument.**

Refer to diagram #5 to use the 25K Pot independently of the pickup output.

By taking the output of the pickup from position H5, the Volume control can be used as a Master Volume with H1 (or H2) and H3 being the input and/or output of the Volume control. H1 and H2 positions are interchangeable.

Position H4, the output of the pickup, would typically go to a selection switch or a pan-pot.

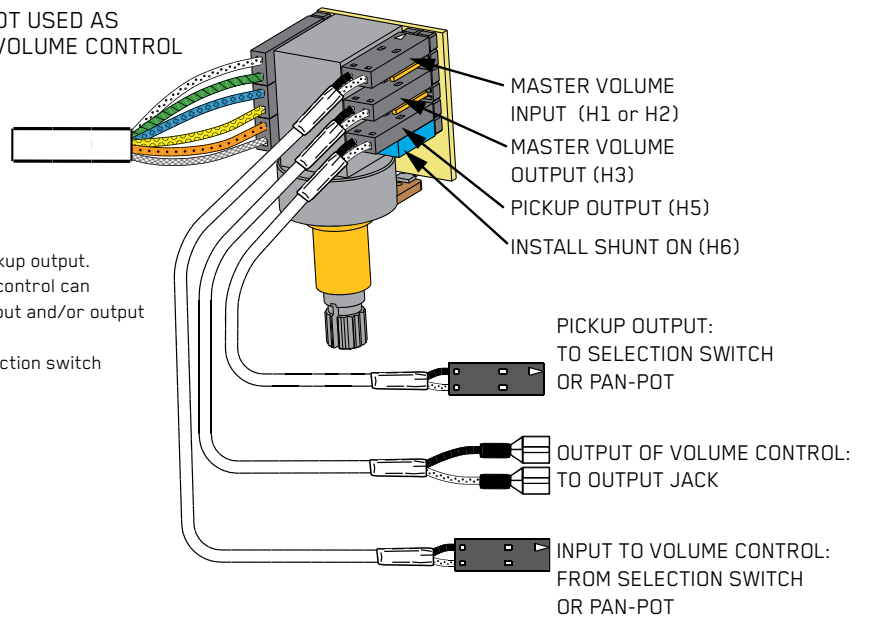

**Diagram #6**  
 PUSH-PULL POT USED AS A MASTER  
 TONE CONTROL

**Using the Pot Section as:**

**A Master Tone control for the Instrument.**

Refer to diagram #6 to use the 25K Pot independently of the pickup output.

By taking the output of the pickup from Position H5, the control can be used as a Master Tone with H1 (or H2) and H3 being the input and/or output of the Tone control. H1 and H2 positions are interchangeable.

Position H5, the output of the pickup, would typically go to a selection switch or a pan-pot.

