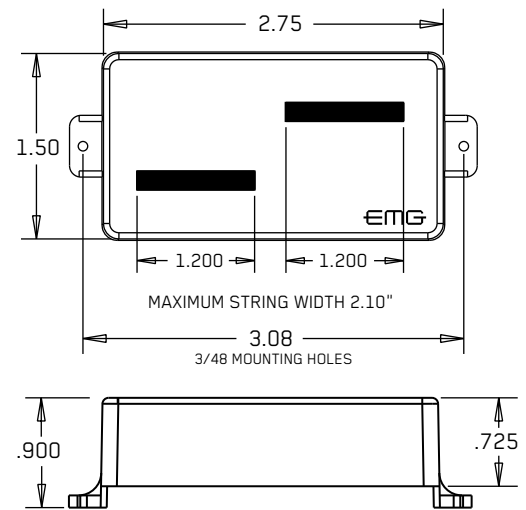

0230-02 53A

PO BOX 4394  
SANTA ROSA, CA  
95402 USAP (707) 525-9941  
F (707) 575-7046  
EMGPICKUPS.COM**X-SERIES**

## INSTALLATION INFORMATION

### EMG MODELS: **EMG-HBX, HBCSX**

#### SPECIFICATIONS:

	MODEL:	
	HBX	HBCSX
Logo Color*	Silver	Silver
Magnet Type **	C	C/S
Resonant Frequency (KHz)	3.20	2.61
Output Voltage (String)	2.00	2.00
Output Voltage (Strum)	8.50	8.50
Output Noise (60 Hz)	-106	-101
Output Impedance (Kohm)	2.00	10
Current @9V (Microamps)	80	80
Battery Life (Hours)	3000	3000
Maximum Supply (Volts DC)	27	27

\*Note: Logo Colors are not distinguished on Chrome and Gold Models

\*\*Note: Magnet Type: A (Alnico) A/S (Alnico/Steel) C (Ceramic) C/S (Ceramic/Steel)

#### INSTALLATION NOTES:

The EMG-HBX is a bass pickup in a standard guitar humbucking housing. It is designed for narrow width 4-string basses only. The drawing above shows the maximum recommended string width. All EMG Pickups are compatible with each other. The connector system is an easy method of installation, avoiding the need to solder. Older systems may need to be soldered, while the newer systems can be easily connected and modified. If you have an older EMG Pickup you can install the new system along with it. EMG accessories like the VLPF, EXB, BTC or BQC Controls can be added to any EMG Pickup System without the need for an extra battery.

#### IMPORTANT INSTALLATION NOTES:

- 1) Only one 9 Volt battery is required to power the pickups and any accessories such as the SPC, RPC, EXG, AB, PA-2, and PI-2.  
Use an Alkaline or Lithium battery for longest life.
- 2) The Volume Control included with the EMG-X System is 25K Ohm.  
This value is required for the system to work correctly.
- 3) A stereo output jack (12B) is included with the EMG-X Pickups; it grounds the black battery wire to turn on the pickups when the plug is inserted into the jack. If you are replacing passive pickups, make sure to use the jack included. If your guitar has a long panel jack (see Page 2, bottom), make sure it is a stereo type, a Switchcraft 152B is recommended.
- 4) When installing any EMG-X Active Pickup, DO NOT connect the bridge ground wire. This wire is usually soldered to a volume or tone control casing and goes to the bridge. This wire grounds the strings and uses them and your body as a shield against hum and buzz. It also creates a shock hazard.
- 5) EMG-X Active Pickups have very little magnetism compared to passive pickups. We recommend you adjust the pickups as close to the strings as possible. Sustain and string movement will not be inhibited by close adjustment.
- 6) If your installation is different from the diagrams in these instructions or you need additional diagrams visit our website: [emgpickups.com](http://emgpickups.com) for a complete listing of available diagrams.
- 7) **SPECIAL NOTE:**  
The diagrams shown are for EMG-X Active Pickups. All diagrams show the Red Wire coming from the pickups connected to the battery. If you are installing EMG-HZ Passive Pickups refer to their diagrams. The Red Wire of the HZ Pickup is NOT for battery power, it is a coil wire.

#### WARRANTY

All EMG Pickups and accessories are warranted for a period of two years. This warranty does not cover failure due to improper installation, abuse or damage. If upon examination the pickup is determined to be defective, a replacement will be made. Warranty replacement products are covered by this same warranty. This warranty covers only those pickups and accessories sold by authorized EMG Dealers. This warranty is not transferable.

## Installation Instructions:

### EMG Models: EMG-HBX, HBCSX

#### General Notes:

Every attempt has been made to make this a solderless installation.

There are some instances where this is not possible;

- 1) If your instrument uses the long panel output jack and you had passive pickups you will need a new stereo output jack, the Switchcraft 152B is recommended. Soldering to the new jack will be required, see page 4.
- 2) Power Supply tips are on page 4. If your instrument has a battery holder, you are installing this pickup with an older EMG, or you want to supply your instrument with +18 Volts, see page 4 for tips to avoid soldering.

If you are installing only one pickup use the instructions on this page.

If you are installing two pickups go to page 3 and begin there.

#### Installation (One Pickup Guitars):

- 1) Plug the pickup cable onto the EMG Pickup header as shown in Diagram #1 and route the cable to the control cavity. If the cable is too long, wind up the excess and keep it under the pickup if possible.

##### Master Volume control only

- 2) Refer to Diagram #2. Plug both the Pickup cable and the output cable onto the Volume control as shown, then go to step 4.

##### Master Volume and Active Tone control

- 3) Refer to Diagram #3.

Install the VLPF Active Tone included with the X Series Pickup.

Plug a coax cable from the Volume control to the Active Tone Control. (Note the reversed connector on pins 1 and 2). Insert the output cable onto the Tone control as shown (Pins 3 and 4).

- 4) Connect the output wires to the output jack by pushing the connectors onto the jack as shown. WHITE wire to the TIP (T) contact, BLACK wire to the SLEEVE (S) contact, BLACK Battery Negative wire to the RING (R) contact.
- 5) Using the battery buss, insert the RED wire of the pickup, the battery RED wire, and the RED wire from the VLPF onto any of the pins. Extra pins can be used for EMG Accessories.
- 6) Put the battery in the insulating foam piece provided and place it securely in the control cavity. We suggest that you plug in the instrument and test it before closing the control cavity.

#### \*\*\*\*Tips and Tricks\*\*\*\*

Start your installation by:

- 1) Read the General Notes on Page 2 if you haven't already and determine if you have the right output jack for your instrument. A Stereo 12B type (Included) or a 152B Long Panel Jack will be required.
- 2) Remove the strings
- 3) Remove any existing Pickups and controls (remember the order and function of each control)
- 4) Install the EMG Volume and Tone Controls and tighten them in.
- 5) Then install the pickups keeping any excess cable under the pickup rather than in the control cavity.

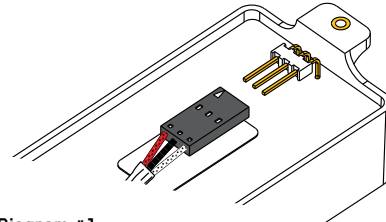

Diagram #1

Insert the plug onto the 3 pin header of the pickup as shown above. Note the orientation arrow.

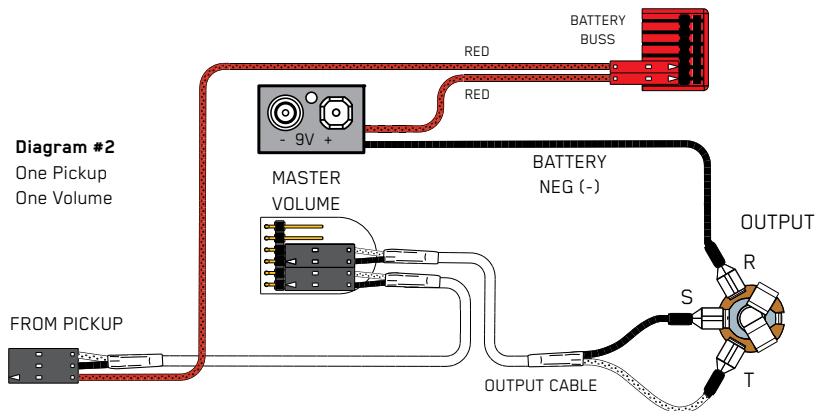

Diagram #2

One Pickup  
One Volume

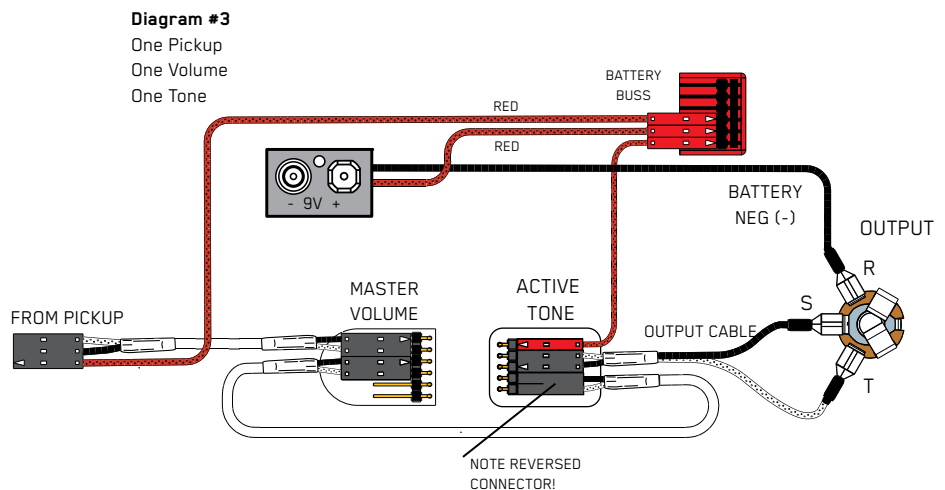

Diagram #3

One Pickup  
One Volume  
One Tone

NOTE REVERSED  
CONNECTOR!

**Installation Instructions:**

**EMG Models: EMG-HBX, HBCSX**

**2 Pickups, 2 Volume controls, VLPF Active Master Tone, no selection switch**

**J-Bass Style wiring**

**Refer to Diagram #4**

- 1) Install the Pickups and route the Pickup cables to the control cavity.  
If the cables are too long, keep any excess under the pickup.
- 2) Mount the Volume and Tone controls into the body / pickguard.  
Plug the Neck Pickup Cable onto the Neck Volume control.  
Plug the Bridge Pickup Cable onto the Bridge Volume control.
- 3) Plug a coax cable from the Neck Volume control to the Bridge Volume Control.
- 4) Plug a coax cable from the Bridge Volume control the VLPF Master Tone control.
- 5) Plug the output cable from the VLPF Master Tone control and connect the output wires to the output jack by pushing the connectors on as shown.  
WHITE wire onto the TIP (T) contact,  
BLACK wire onto the SLEEVE (S) contact  
BLACK Battery Negative wire onto the RING (R) contact.
- 6) Plug the RED Wires of the pickups onto the V+ Supply Buss (RED Shroud) along with the RED of the battery clip.
- 7) Put the battery in the insulating foam piece provided and place it securely in the control cavity.  
We suggest that you plug in the instrument and test it before closing the control cavity.

**Diagram #4**  
**Volume / Volume**  
**Master Tone (Passive)**

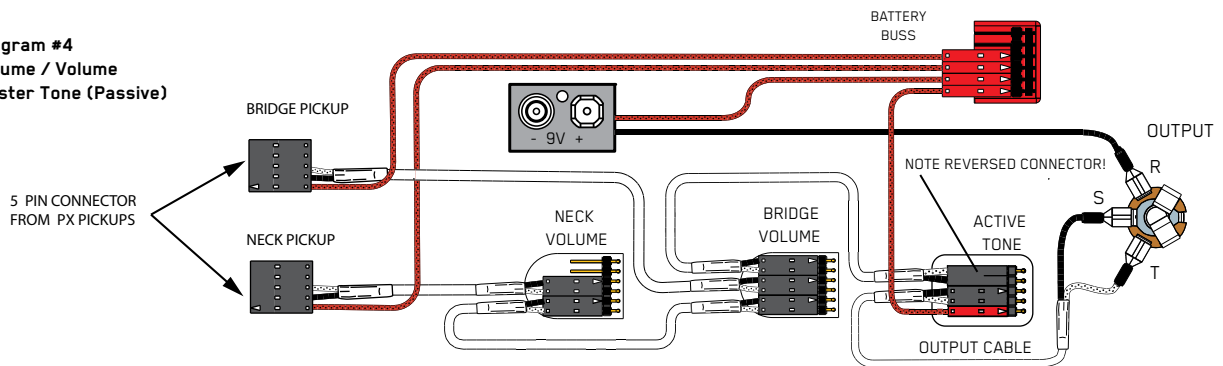

**Diagram #5 (preferred wiring order)**

**B118 Active Balance Control**  
**Active Tone / Master Volume**

This installation can be used for instruments with 3 control positions like the diagram above, but use a Balance control instead of 2 Volume controls. The VLPF Active Tone Control shown in this diagram can be replaced with the EMG-EXB Expander, EMG-BTC Control (Active Bass and Treble EQ) or the VMC.

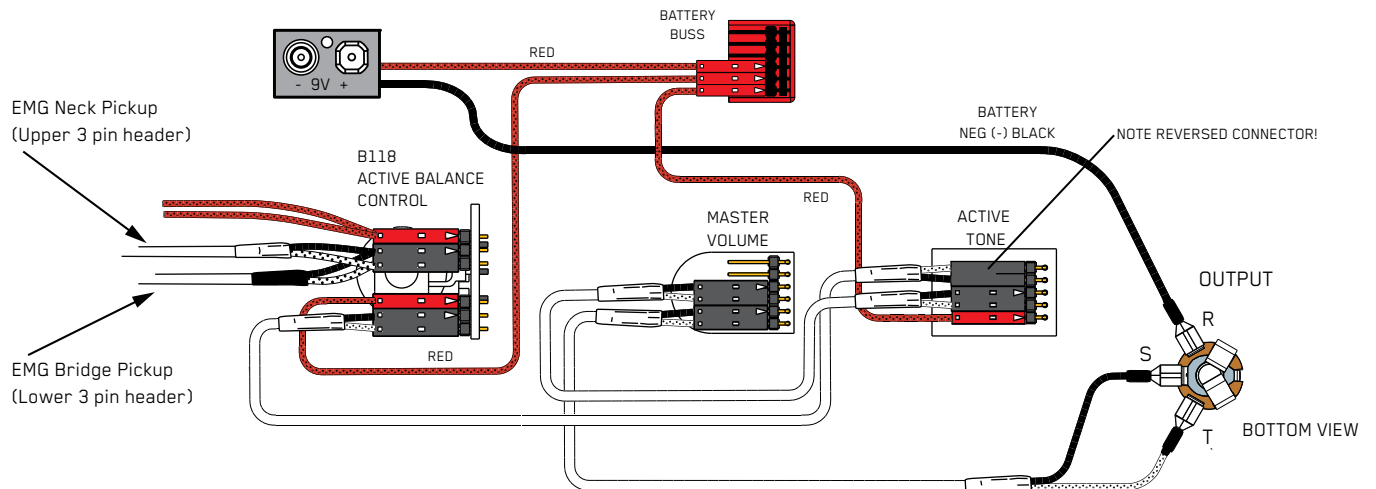
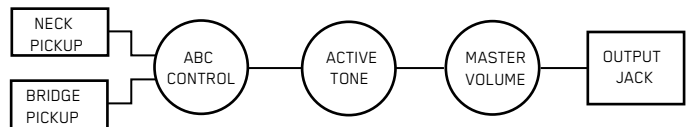

**Using the B157 Pickup Bus:**

If your instrument has 2 Pickups and a selection switch you will be using the B157 Pickup Bus to send the pickup signals to the selection switch. Refer to the B157 Instructions included.

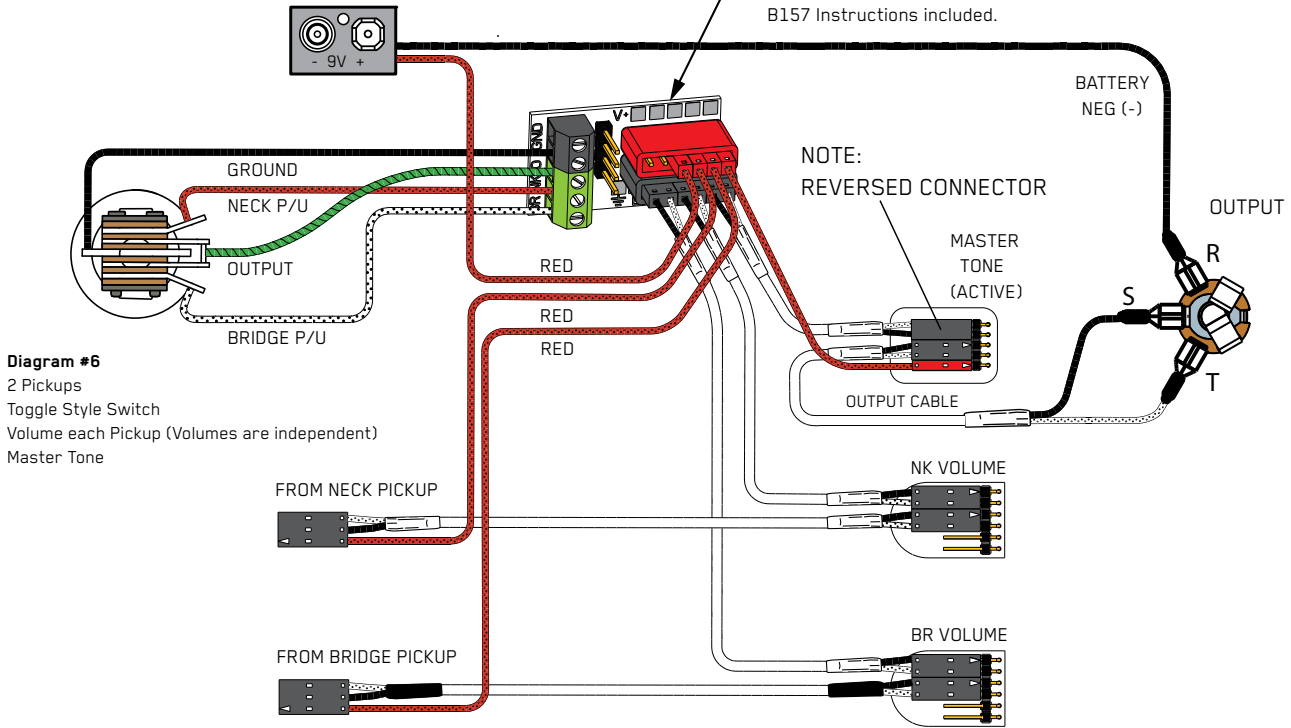

**Diagram #6**  
2 Pickups  
Toggle Style Switch  
Volume each Pickup (Volumes are independent)  
Master Tone

**Diagram #7**

**Soldering to the 152B Panel Jack:**

If your instrument has a long Panel Jack like the one below you will have to solder the output cable as shown.

- Ground (Black) to the sleeve
- Signal (White) to the Tip
- Battery Negative (Black) to the Ring

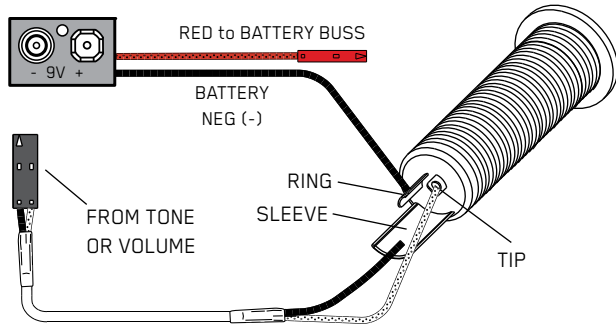

**Diagram #8**

**Soldering to the battery buss:**

If your instrument has an older EMG Pickup you can solder the pickup RED wire to the buss. Simply use some needle nose pliers, pull out the V+ header and solder the RED Wire from the pickup(s) to any of the pins and then re-insert the header into the housing.

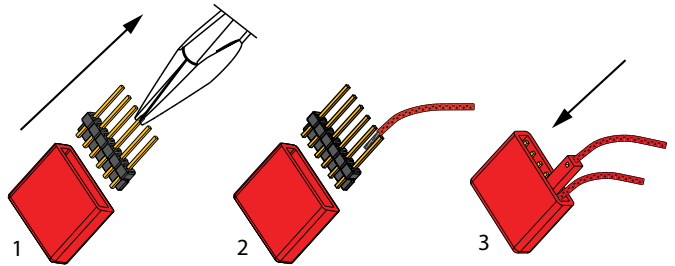

**Diagram #9**

**If the instrument has a Battery Holder:**

If your instrument has a 9 or 18 Volt battery holder you can still use the EMG Connectors to supply power to the pickups. Simply cut and strip the wires from the battery clip provided. Twist the wires together (Red to Red and Black to Black) and use the shrink tubing included to cover the connections. Soldering the wires is recommended.

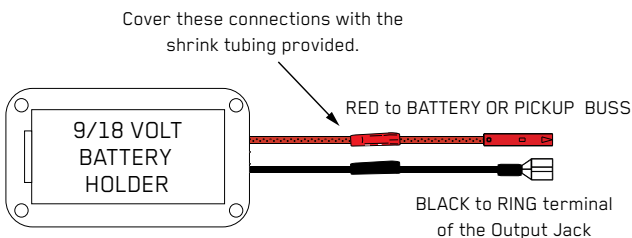

**Diagram #10**

**+18 Volt Wiring Option:**

If you want to operate your instrument at +18 Volts for more headroom then use 2 batteries wired as below. Also, if you are using any type of EQ in your instrument (EMG-BT, BQ) or anything that boosts the pickup signal then +18 Volts is recommended.

